

**SHINING 3D Metrology Solutions**  
Going Beyond Precision

# CATALOGUE

## 01

### Core Technologies & Certifications

Core Technologies Introduction  
and Related Certifications / 1

## 02

### Handheld 3D Scanner

FreeScan Combo Series / 2-3  
FreeScan UE Pro Series / 4-5  
FreeScan Trio / 6-7

## 03

### Optical 3D Measuring & Dynamic Tracking System

FreeScan Trak ProW / 8-9  
FreeScan Trak Nova / 10-11  
FreeScan Trak Pro2 / 12-13

## 04

### High Precision 3D Inspection System

OptimScan Q12 / 14-15  
OptimScan 5M Plus / 16

## 05

### 3D Software

3D Inspection Software  
Reverse Engineering Software / 17

## 06

### Solutions

Automotive / 18  
Aerospace / 19  
Engineering Machinery / 20  
Energy / 21  
Electronic & Electrical / 22  
Casting & Sheet Metal / 23  
Tooling & Injection Molding / 24

## 07

### About SHINING 3D / 25



# High-Accuracy 3D Vision Technology



## Accuracy Laboratory

The SHINING 3D Accuracy Laboratory has been accredited the ISO/IEC 17025:2017 certification by CNAS. In the Accuracy Laboratory, the calibration procedures strictly follow the VDI/VDE 2634 standards, ensuring that its technical capabilities can provide reliable quality assurance for enterprise, industry, and customer product research, testing, and manufacturing.



# FreeScan Combo Series

Hybrid Light Source and Multifunctional Handheld 3D Scanner



reddot winner 2024

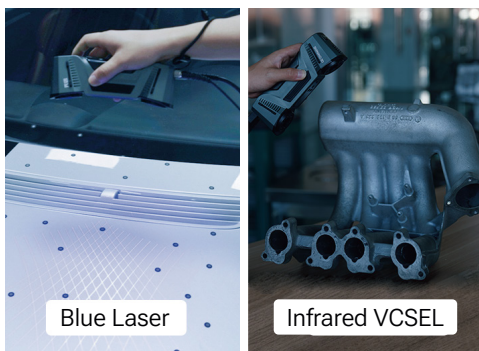

## Blue Laser + Infrared Light

An innovative combination of blue laser and infrared light sources meet the needs of diverse industrial 3D scanning scenarios.

## Infrared Mode Scan without Markers

No markers needed for feature-rich workpieces. Infrared light source can be used directly to scan surfaces quickly.

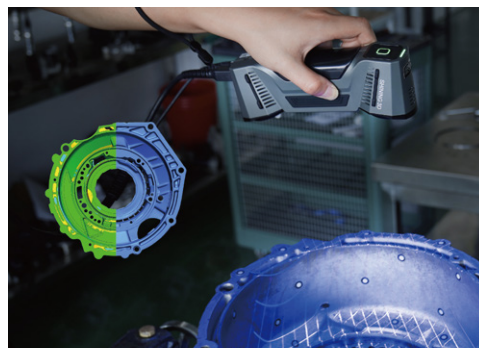
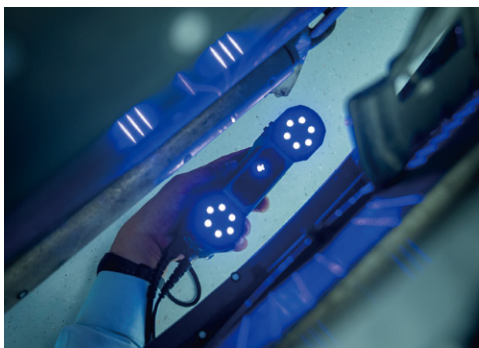

## Working in Confined Spaces

The FreeScan Combo series are able to work in confined spaces. The lens angle is optimized to acquire full data on narrow seams.

## Light Weight and Compact

Small size of 193 x 63 x 53 mm and weight only of 620g.



**FreeScan Combo+**

**50 Laser Lines**

**FreeScan Combo**

**26 Laser Lines**

## Technical Specification

	<b>FreeScan Combo Series</b>
<b>Light source</b>	Blue Laser & Infrared VCSEL
<b>Accuracy</b>	0.02 mm
<b>Max. FOV</b>	520 x 510 mm / 600 x 600 mm
<b>Volumetric accuracy</b>	0.02 + 0.033 mm/m
<b>Point distance</b>	0.05 ~ 10 mm / 0.1 ~ 3 mm
<b>Scan speed</b>	Up to 3,600,000 points/s
<b>Dimension</b>	193 x 63 x 53 mm
<b>Weight</b>	620 g
<b>Certifications</b>	CE, FCC, ROHS, WEEE, FDA, UKCA, IP50, KC, TiSAX
<b>Accuracy certification</b>	VDI/VDE 2634 Part3 (certificated in ISO 17025 certificated accuracy lab)

# FreeScan UE Pro Series

Multi-Functional Laser Handheld 3D Scanner



reddot winner 2024

FreeScan UE Pro2

50 Laser Lines

FreeScan UE Pro

26 Laser Lines

## Technical Specification

### FreeScan UE Pro Series

Light source	Blue Laser
Accuracy	0.02 mm
Max. FOV	600 × 550 mm
Volumetric accuracy	0.02 + 0.03 mm/m (standard mode) - 0.02 + 0.015 mm/m (built-in photogrammetry mode)
Point distance	0.01 ~ 10 mm
Scan speed	Up to 3,460,000 points/s
Dimension	298 × 103.5 × 74.5 mm (FreeScan UE Pro2) / 305.8 × 118.9 × 100.8 mm (FreeScan UE Pro)
Weight	950g (FreeScan UE Pro2) / 840g (FreeScan UE Pro)
Certifications	CE, FCC, ROHS, WEEE, KC, FDA, UKCA, IP50, TELEC, TISAX
Accuracy certification	VDI/VDE 2634 (certificated in ISO 17025 certificated accuracy lab)



## ▪ FreeScan UE Pro2

Inspect on the move

### Wireless and Portable

Integrated with Wireless module, FreeScan UE Pro2 liberates you from cables, allowing seamless data transmission during scanning.

### Double the Speed, Double the Productivity

FreeScan UE Pro2 offers nearly double scanning efficiency compared to the previous generation. With a lightning-fast scan speed up to 3,460,000 points/s.

### Certified and Guaranteed Results

0.02 mm accuracy delivers consistent scanning results with high precision.

### Binocular Photogrammetry: Elevated Accuracy for Large-scale Scans

FreeScan UE Pro series feature patented innovative built-in photogrammetry technology for scanning large objects, quickly optimizing the spatial position of global markers, ensuring consistent accuracy.

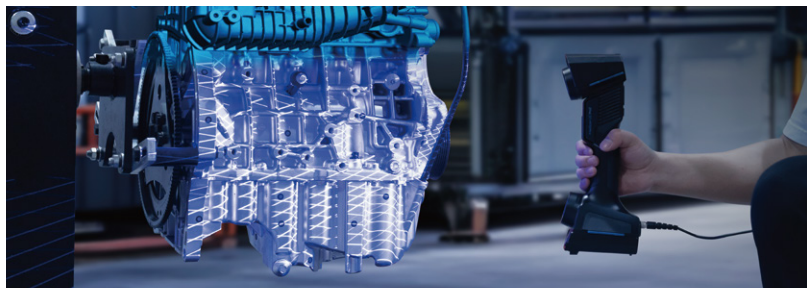

# FreeScan Trio

First Marker-Free Laser 3D Scanner

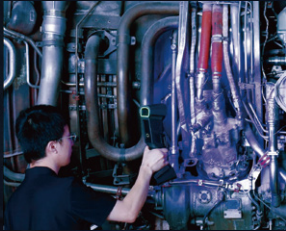

## 98 Laser Lines, Zero Markers

The FreeScan Trio's thorough 98-laser-line mode eliminates the need for markers, efficiently capturing all your workpieces.



## Three 5 Megapixel Cameras

With 3 industrial cameras, each wielding 5 mega pixels, FreeScan Trio brings out the most elaborate details and high-quality 3D data.

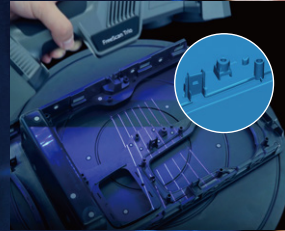

## Unrelenting Accuracy and Precision

For quality control, inspection, and reverse engineering, its 0.02 mm accuracy (with markers) and high-precision performance deliver results you can count on, time and time again.



## Patented Photogrammetry

The FreeScan Trio features a binocular photogrammetry mode that can achieve a remarkable volumetric accuracy of up to 0.02 mm + 0.015 mm/m.

## Technical Specification

	FreeScan Trio
Light source	26 laser lines, Single laser line, 7 parallel laser lines, 98 laser lines
Accuracy	0.02 mm
Max. FOV	650 x 580 mm
Volumetric accuracy	0.02 + 0.03 mm/m (0.02 + 0.015 mm/m with photogrammetry)
Point distance	0.01 ~ 3 mm
Scan speed	Up to 3,010,000 points/s
Dimension	331 x 120 x 76 mm
Weight	985g
Certifications	CE, FCC, ROHS, WEEE, KC, FDA, UKCA, IP50, TISAX
Accuracy certification	VDI/VDE 2634 (certificated in ISO 17025 certificated accuracy lab)



FreeScan Trio

# FreeScan Trak ProW

Wireless 3D Dynamic Tracking and Scanning System with Expanded Range

## Technical Specification

	FreeScan Trak ProW
Accuracy	0.023 mm
Volumetric accuracy (based on measuring)	15.6 m <sup>3</sup> : 0.046 mm; 45 m <sup>3</sup> : 0.063 mm; 76 m <sup>3</sup> : 0.088 mm; 128 m <sup>3</sup> : 0.127 mm
Volumetric accuracy with VPG	0.044 + 0.012 mm/m (extension volume)
Scan speed	5,500,000 points/s
Resolution	0.01 ~ 10 mm
High-speed scan	Included (50 laser lines)
Detailed scan	Included (7 parallel laser lines)
Deep pockets scan	Included (1 laser line)
Weight	FreeTrak W: 8.2 kg; TE25W: 1.47 kg
Connection	Wireless & Wired mode (fiber optic)
Certifications	CE, FCC, ROHS, WEEE, KC, FDA, UKCA, IP50, TELEC, TISAX
Acceptance test	VDI/VDE 2634 Part3 (certificated in ISO 17025 certificated accuracy lab)



### Ultra-Wide Measuring Range

FreeScan Trak ProW features a groundbreaking design with an ultra-long 8.6 m tracking distance and widely expands the single-station tracking volume to 206.7 m<sup>3</sup>, significantly reducing the need for leapfrog during large-scale object scanning.



### Wireless Scanning Wherever You Go

FreeScan Trak ProW delivers fast, wireless scanning anywhere. Its cable-free design enables real-time data transfer, with power bank support for unrestricted mobility. An integrated screen ensures seamless operation.



### Video Photogrammetry (VPG)

FreeScan Trak ProW features SHINING 3D's patented video-based photogrammetry, which eliminates the need for coded markers. This ensures consistent volumetric accuracy and streamlines the setup process for efficient large-object scanning.



### No Markers Needed, Fast Paced Scanning

FreeTrak W enables real-time TE25W scanner recognition and positioning, eliminating the need for reference markers, which enhances scanning efficiency and streamlines the workflow, while ensuring rapid data acquisition with a scanning speed of up to 5,500,000 points per second.

# FreeScan Trak Nova

Wireless Multi-Functional  
Dynamic Tracking and Scanning System

TE Nova

UE Nova

## Technical Specification

	FreeScan Trak Nova	FreeScan UE Nova
Accuracy	0.02 mm	0.072 mm
Volumetric accuracy	0.062 mm (12m³)	/
Volumetric accuracy with VPG	0.046 + 0.012 mm/m (extension volume)	0.072 + 0.012 mm/m
Resolution	0.01 ~ 10 mm	0.5 ~ 10 mm
Scan speed	6,140,000 points/s	4,600,000 points/s
Flexible FOV	Up to 2600 x 2200 mm	
VPG	Included (no coded markers required)	
FOV indicator of VPG	Included	
High-speed scan	Included (50 laser lines)	Included
Detailed scan	Included (7 parallel laser lines)	Included (support near mode)
Deep pockets scan	Included (1 laser line)	/
Depth of field	TE Nova 380 mm (170 ~ 550 mm) UE Nova 2700 mm (800 ~ 3500 mm)	2300 mm (300 ~ 2600 mm)
Connection	Wireless & Wired mode (fiber optic)	
Net weight	TE Nova: 1.2 kg / UE Nova: 1.6 kg	
Certifications	CE, FCC, ROHS, WEEE, KC, FDA, UKCA, IP50, TELEC, TISAX	
Acceptance test	VDI/VDE 2634 Part3 (certificated in ISO 17025 certificated accuracy lab)	

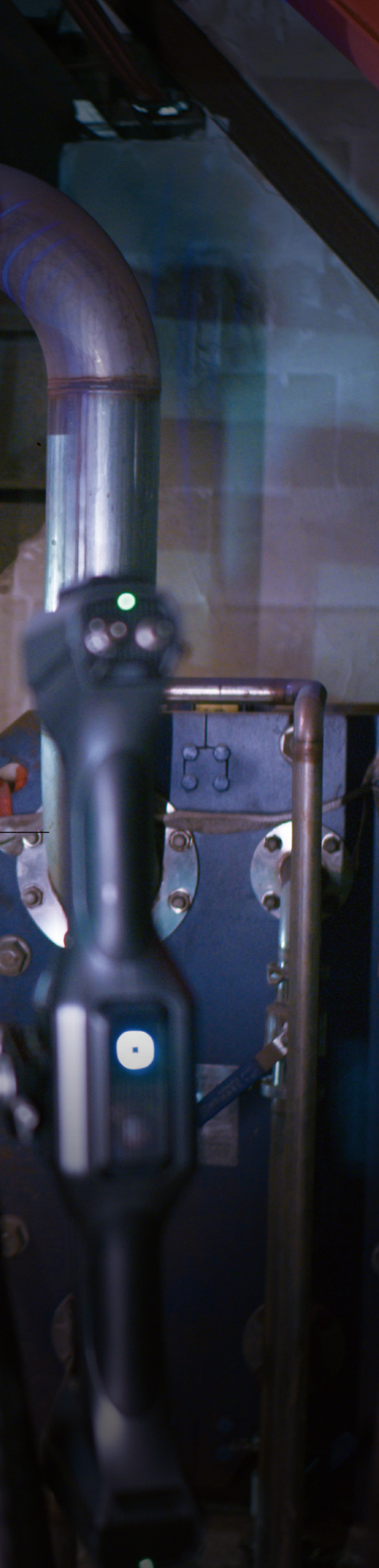

## ▪ FreeScan Trak Nova

Small in Form, Big on Performance



### **Dynamic Tracking Scan: Compact and Agile**

The real-time tracking technology allows for the capture of fine details. With its wireless and compact design, the system excels in scanning confined spaces, ensuring efficient and precise measurements.



### **Flexible & Separable System**

FreeScan Trak Nova includes a detachable handheld scanner. The tracker, FreeScan UE Nova, also serves as a handheld laser scanner with the largest FOV on the market, delivering unparalleled efficiency and flexibility.

## ▪ FreeScan UE Nova

Wireless Metrology 3D Scanner for Greater Reach



### **Flexible FOV**

FreeScan UE Nova offers the flexible field of view depending on three selectable working range, adapt to different on-site operation conditions.

- Near Mode (300 ~ 800 mm)
- Standard Mode (600 ~ 1500 mm)
- Far Mode (1200 ~ 2600 mm)



### **Wide-Range Laser Scan: Vast and Fast**

FreeScan UE Nova offers expansive coverage, delivering unparalleled efficiency and flexibility.

- Large-scale scanning coverage: FOV of 2.6 × 2.2 m
  - Maximum scanning distance of 2.6 m
- 50 Laser Lines for rapid scanning, enabling fast data capture and significantly reducing scanning time.

# FreeScan Trak Pro2

Optical 3D Measuring and Dynamic Tracking without Markers

## Technical Specification

	FreeScan Trak Pro2	FreeProbe (optional)
<b>Light source</b>	FreeTrak: Infrared LED TE25: 50 cross laser lines, 7 parallel laser lines, Single laser line	/
<b>Accuracy</b>	0.023 mm	0.025 mm
<b>Max. FOV</b>	650 x 580 mm	/
<b>Volumetric accuracy</b>		9.6 m <sup>3</sup> : 0.062 mm 17.6 m <sup>3</sup> : 0.072 mm
<b>Point distance</b>	0.01 ~ 10 mm	/
<b>Scan speed</b>	Up to 3,070,000 points/s	100 measurements/s
<b>Dimension</b>	FreeTrak: 1079 x 237 x 110 mm TE25: 281 x 283 x 290 mm	70 x 150 x 340 mm
<b>Weight</b>	FreeTrak: 7.2 kg TE25: 1.47 kg	0.5 kg
<b>Certifications</b>	CE, FCC, ROHS, WEEE, KC, FDA, UKCA, TISAX	
<b>Accuracy certification</b>	VDI/VDE 2634 (certificated in ISO 17025 certified accuracy lab)	

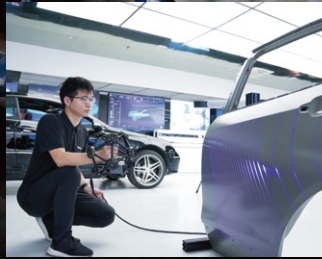
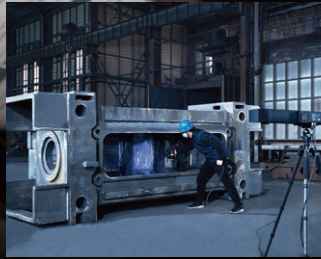

**No Markers Needed**

The FreeTrak bar dynamically tracks the TE25 scanner thanks to its tracking targets, without the need to manually place markers on the scanned object. This markerless operation saves time and makes 3D scanning process much smoother.

**Wide Measuring Range**

FreeScan Trak Pro2's wide and expandable tracking range allows measurement of a broad spectrum of volumes and surfaces without compromising accuracy or requiring traditional leapfrogs in the scanning process.

**High-Speed Scanning**

Paired with its 50 blue laser lines, the Trak Pro2's two industrial-grade cameras of 5.0MP each enable ultra-high-speed data acquisition for a smooth scanning experience.

**Supports Both Optical Tracking and Marker Scanning**

Switch between these two modes based on your requirements and the type of object to scan. This duality offers the flexibility to cover a wider range of applications and surface types.

# OptimScan Q12

## High-Precision 3D Inspection Scanner



### 4×12.3MP Cameras, Dual Scan Range

OptimScan Q12 features two scan ranges that can be switched with a single click, eliminating manual adjustment of aperture and focal length. Scanned data from different ranges can be seamlessly fused in the software, ensuring both efficiency and detail.

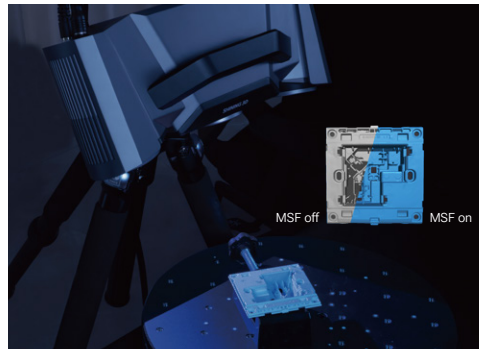

### Monocular-Stereo Fusion (MSF)

The monocular-stereo fusion function can effectively increase data coverage and improve the integrity of the scanned data, such as the common turning corners and joints of industrial parts.



### Multiple Exposure, Faster Scanning

Powered by a built-in dual-chip computing module, OptimScan Q12 delivers fast image acquisition and data processing. Each shot less than 1 second, capturing an impressive 12 million points with exceptional precision. To further streamline the workflow, Q12 offers multiple exposure modes—including intelligent automatic exposure—dramatically reducing scanning time while ensuring optimal results across diverse surface conditions.



### Automated Inspection Solution

OptimScan Q12 can seamlessly integrate with intelligent 3D inspection system, enabling fully automated workflow from scanning to report generation.

#### Workflow

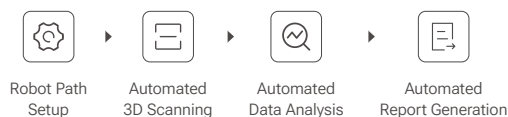



## Technical Specification

	OptimScan Q12	
	Large range	Small range
Scan range	Large range	Small range
FOV	430 × 300 mm	160 × 110 mm
Accuracy	0.015 mm	0.005 mm
Point distance	0.1 mm	0.04 mm
Working distance	590 mm	210 mm
Depth of field	300 mm	60 mm
Resolution	4 × 12.3MP	
Light source	Blue LED	
Weight	OptimScan Q12: 3.5 kg	
Dimensions	366 × 162 × 132 mm	
Certifications	CE, FCC, ROHS, WEEE, KC, FDA, UKCA, IP50, TELEC, TISAX	
Acceptance test	VDI/VDE 2634 Part2 (certified in ISO 17025 certified accuracy lab)	

# OptimScan 5M Plus

## High-Precision 3D Inspection System

### High Resolution

Three sets of 5 megapixel high resolution cameras and 1080P projection are used to obtain high precision features.

### High Accuracy

Single shot accuracy 0.005 mm, scanner provides the function of environmental vibration detection and effectively ensures high quality data and precision.

### Multiple Scan Range

The system realizes different scanning range by switch of different lenses to ensure a finer scanning performance.



## Technical Specification

	OptimScan 5M Plus 400	OptimScan 5M Plus 200	OptimScan 5M Plus 100
Light source	Blue Light (LED)		
Accuracy	0.015 mm	0.01 mm	0.005 mm
Max. FOV	400 x 300 mm	200 x 150 mm	100 x 75 mm
Point distance	0.16 mm	0.08 mm	0.04 mm
Scan speed	≤1.5 s		
Dimension	435 x 300 x 200 mm		
Weight	6.8 kg		
Certifications	CE, FCC, ROHS, WEEE, FDA, UKCA, IP50, TiSAX		
Accuracy certification	VDI/VDE 2634 (certificated in ISO 17025 certificated accuracy lab)		

# 3D Inspection Software



## PolyWorks | Inspector

The 3D dimensional analysis and quality control solution to gain control of your product engineering and manufacturing process.

- ✓ Powerful Measurement and Analysis Capabilities
- ✓ Comprehensive Compatibility and Integration
- ✓ Automated and Customizable Workflows

# 3D Design Software



## EXModel

EXModel is a powerful bridge that simplifies CAD modeling from 3D scanning to manufacturing. It provides a comprehensive set of tools that enable you to transform mesh into a professional quality CAD solid model in easy steps.

- ✓ Effortless Mesh Processing
- ✓ Precision CAD Creation
- ✓ Enhanced Data Utilization



## BlueStar Mapping

Through intelligent and semi-automated workflows, BlueStar Mapping precisely maps multi-angle photos captured by smartphones or DSLR cameras onto 3D scanned models, generating 3D models with high precision, exceptional clarity, and true-color textures.

- ✓ Universal Compatibility
- ✓ One-Stop Workflow
- ✓ High Definition Resolution

# Automotive

In the realm of automotive modification, parts customization, and repairs, the prevailing challenges often manifest as time-consuming procedures, intricate complexities, and the arduous task of achieving absolute vehicle compatibility. Yet, through the utilization of cutting-edge technology such as the SHINING 3D scanner, a remarkable enhancement is achieved.

## Application Fields



Sheet Metal Inspection



Prototype Design



Molding Process Inspection



Collision Testing and Safety Analysis



Casting Component Check



Parts Position and Fitting

## Automotive Door Inspection

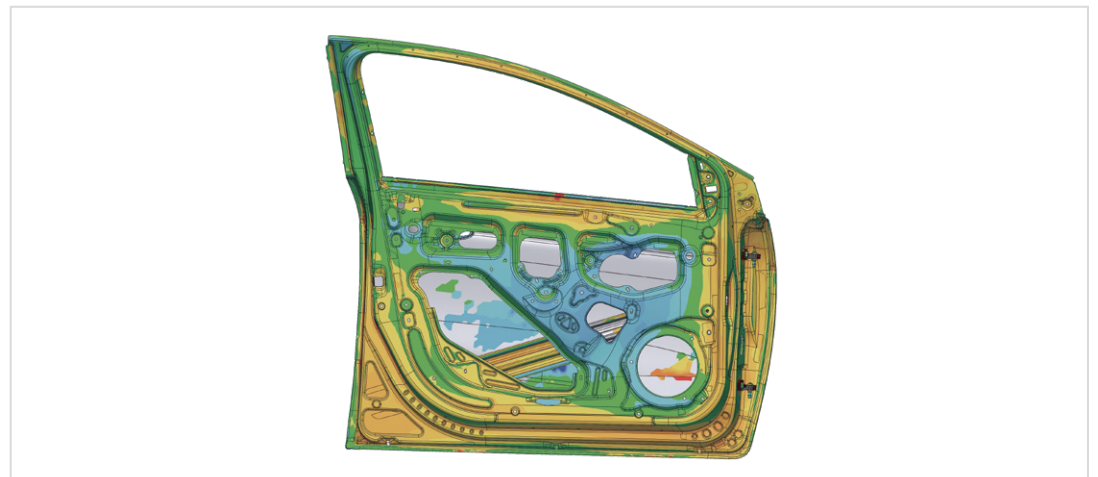
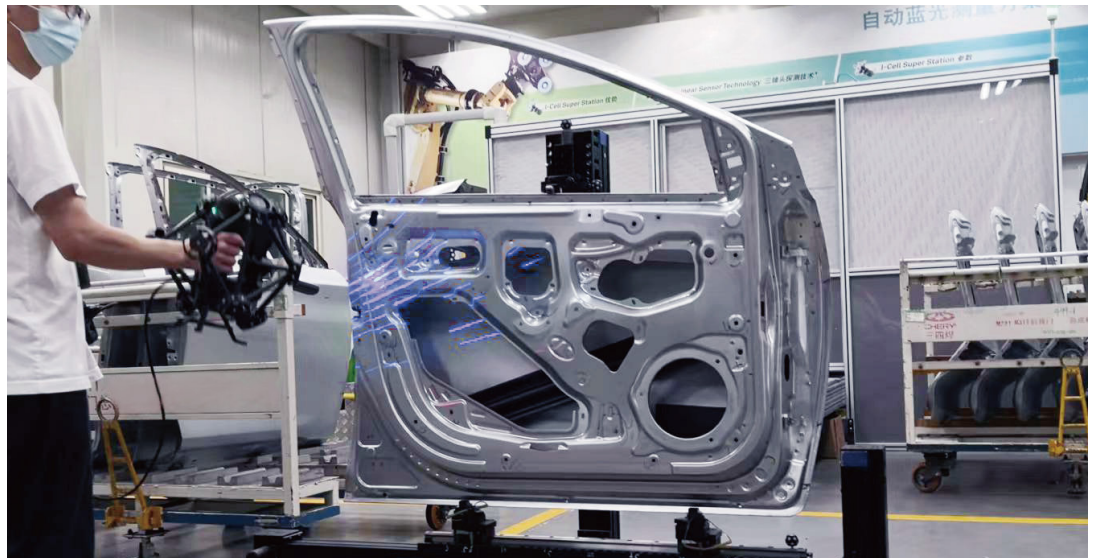

# Civil Aviation

SHINING 3D scanners provide high-precision, visual solutions to meet the inspection requirements of aerospace manufacturing. A non-contact inspection scheme can effectively avoid the possibility of damage to the workpiece and complete deviation analysis in a short period of time.

## Application Fields



Component Digitization



Tooling and Moulds Creation



Dimensional Verification



Blade Inspection



Damage Assessment



Wear Analysis

## Aero-engine Blade Inspection

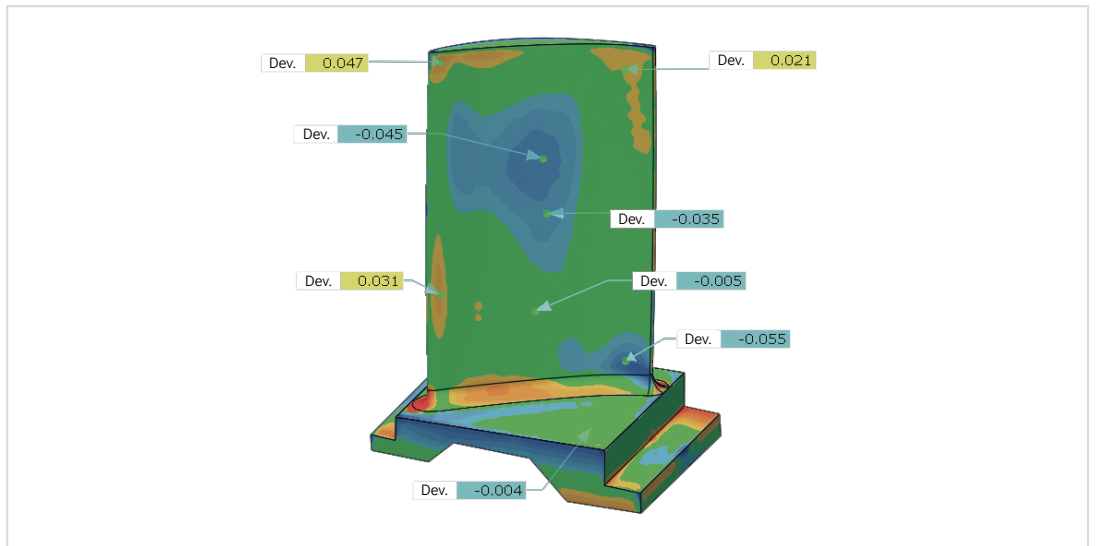
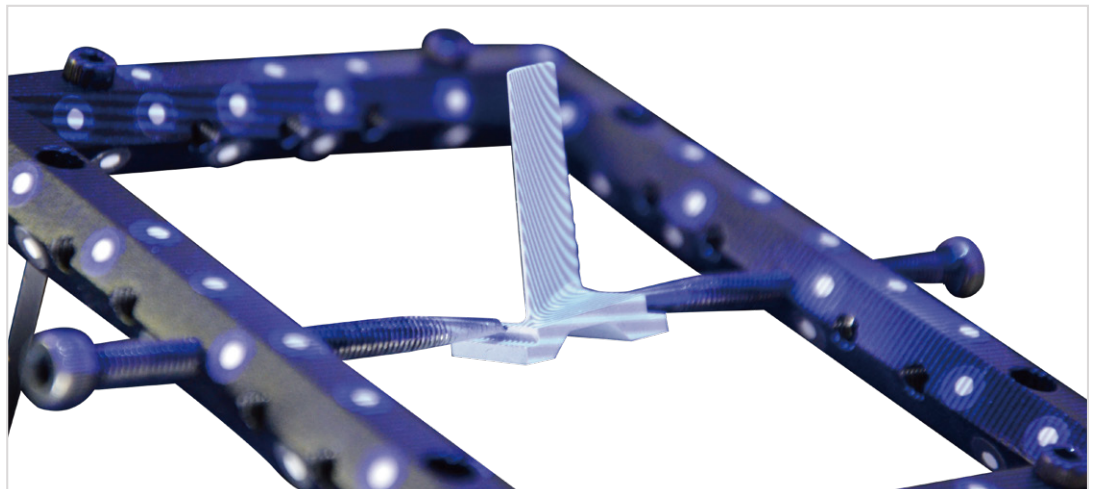

# Engineering Machinery

The engineering machinery industry involves the design, production, and maintenance of machinery used in construction and mining. Pain points include high maintenance costs, equipment downtime, and precision requirements. SHINING 3D scanners provide accurate measurements for wear and tear analysis, enabling predictive maintenance, and ensuring precise fitting of components, thereby reducing downtime and improving overall efficiency.

## Application Fields



Production Control



Train Maintenance



Vibration Analysis



Shipbuilding Quality Control



Shape and Dimension Control

## Giant Mining Trucks Inspection

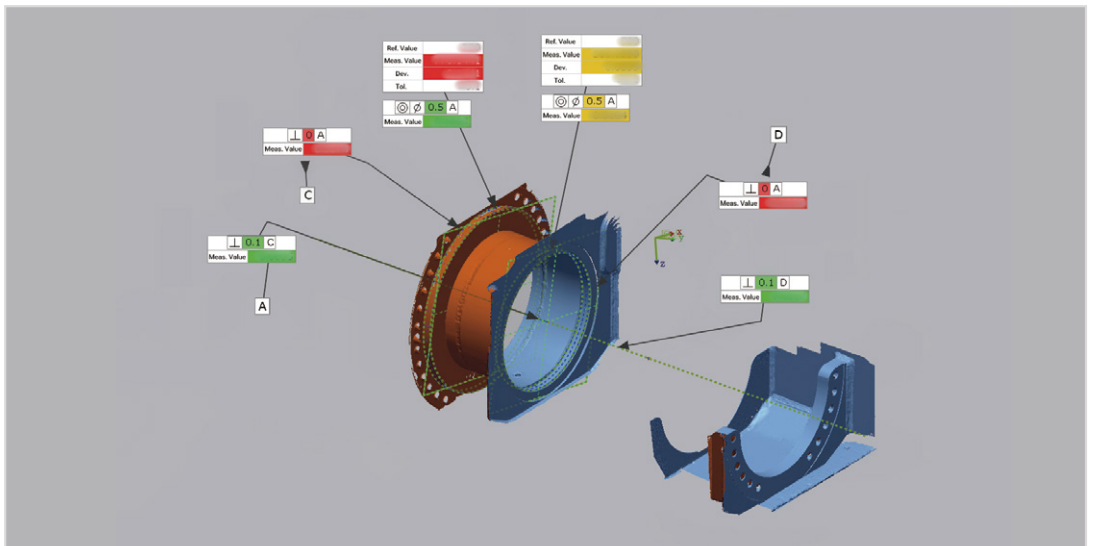

# Energy

Industrial parts involved in the energy industry are subject to strict quality control and GD&T data collection requires high accuracy. In daily use, parts may experience wear and tear, and maintenance of large industrial parts is often costly. SHINING 3D scanners offer a non-destructive solution for measurement, flaw detection and GD&T data acquisition of large industrial parts.

## Application Fields



CFD  
Analysis



Maintenance  
Repare Overhaul



Gas & Turbines  
Analysis



Geometry and  
Construction Control



Water Turbines for  
Generation Inspect

## Wind Power Equipment Mold Inspection

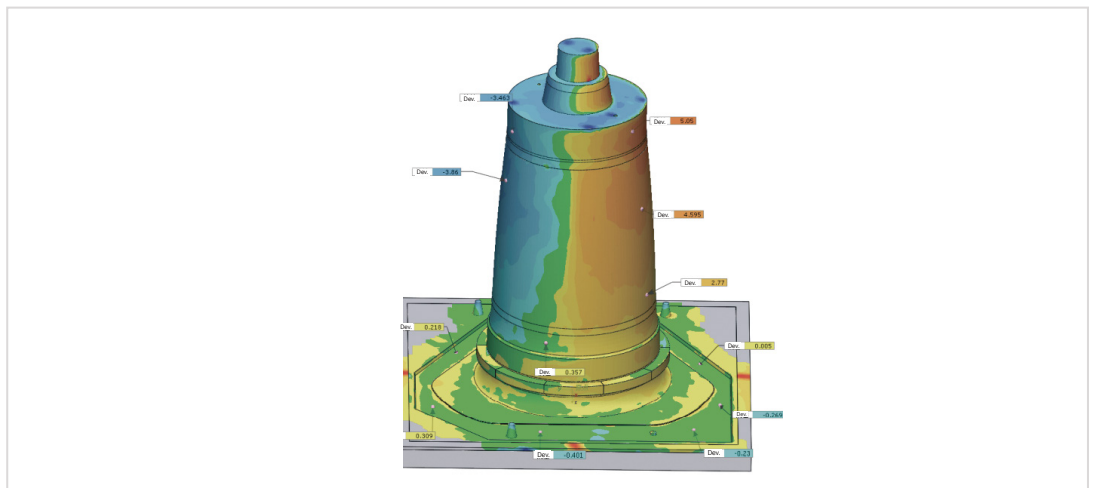

# Electronic & Electrical

Quality control in consumer electronics production involves implementing measures to ensure that products meet specified quality standards throughout the manufacturing process. This typically includes various stages such as incoming materials inspection, in-process testing, and final product evaluation. SHINING 3D scanners are suitable for accurate 3D data acquisition of multi-category precision electronic parts, facilitating 3D full-size inspection.

## Application Fields



PCB Inspection



Component Placement Verification



Thermal Analysis Using 3D Scanning



Electronic Enclosures Modeling



Electronic Components Reverse Engineering



Consumer Electronics Virtual Prototyping

## Smartphone Accessories Inspection

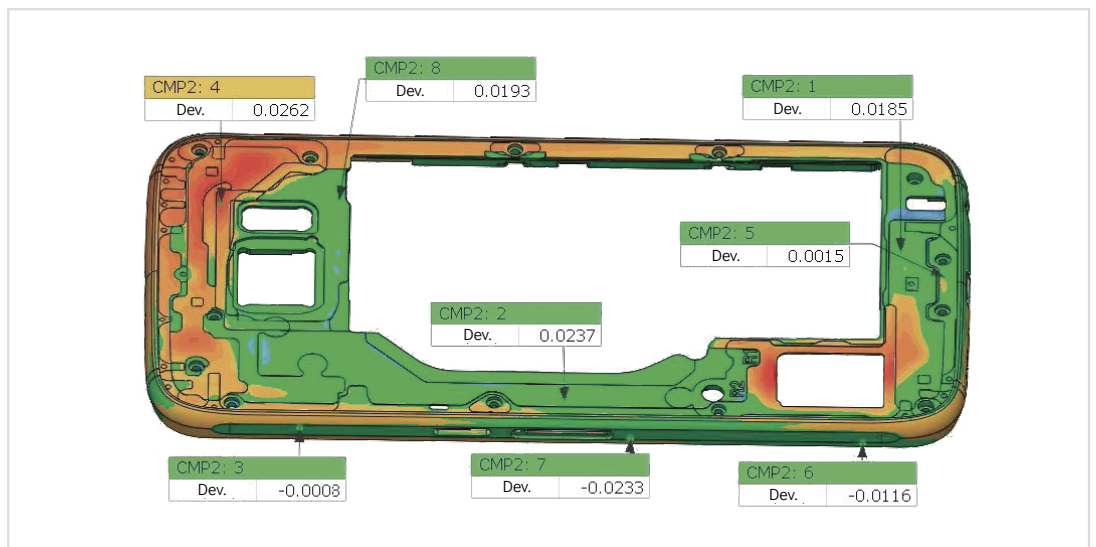

# Casting & Sheet Metal

The foundry and sheet metal industries are involved in the dimensional accuracy of metal parts, detecting defects and maintaining quality control. SHINING 3D scanners provide accurate data to support steps such as measurement and rapid detection of defects.

## Application Fields



Parts Dimensional Inspection



Surface Defect Detection



Sheet Metal Forming Analysis



Precision Casting Quality Control



Metal Parts Reverse Engineering



Tool Path Optimization Using 3D Models

## Large Gas Turbine Castings Inspection

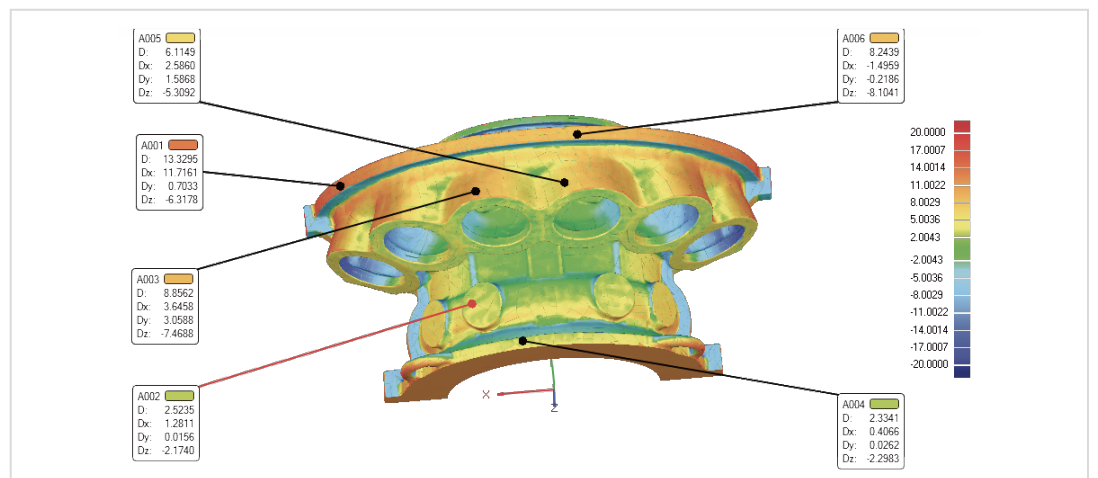

# Tooling & Injection Molding

The Tooling & Injection Molding Industry involves creating molds and tools for producing plastic parts through injection molding. Key pain points include ensuring precision, reducing production time, and minimizing defects. SHINING 3D scanners provide accurate measurements for mold verification, enabling rapid prototyping, and ensuring quality control. This technology enhances precision, speeds up the development process, and reduces waste, ultimately improving overall efficiency and product quality.

## Application Fields



Mold & Tool  
Design Verification



Part  
Validation



Shrinkage and  
Warpage Analysis



Mold Wear and  
Tear Monitoring



First Article  
Inspection



Virtual Simulation of  
Injection Molding Process

## Middle and Large-sized Precision Mold Inspection

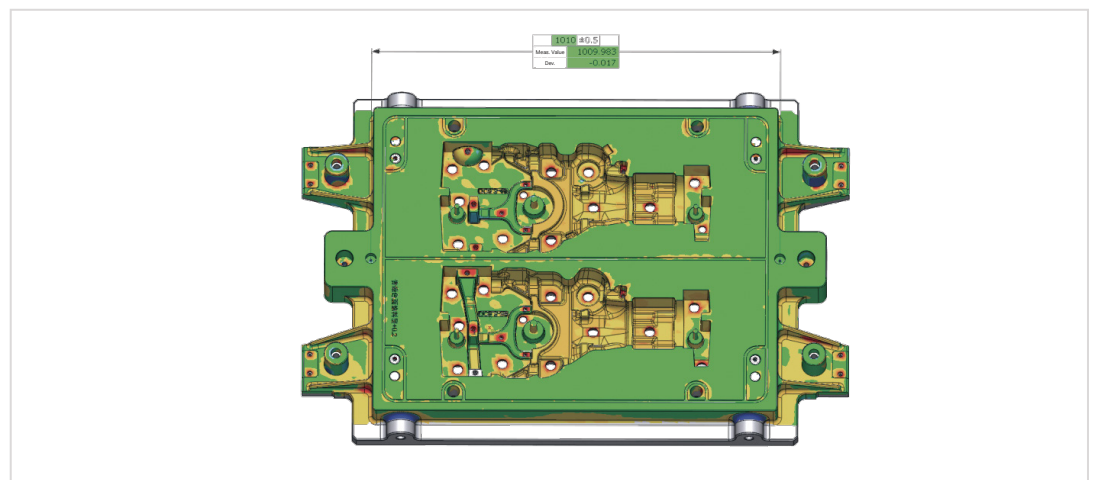
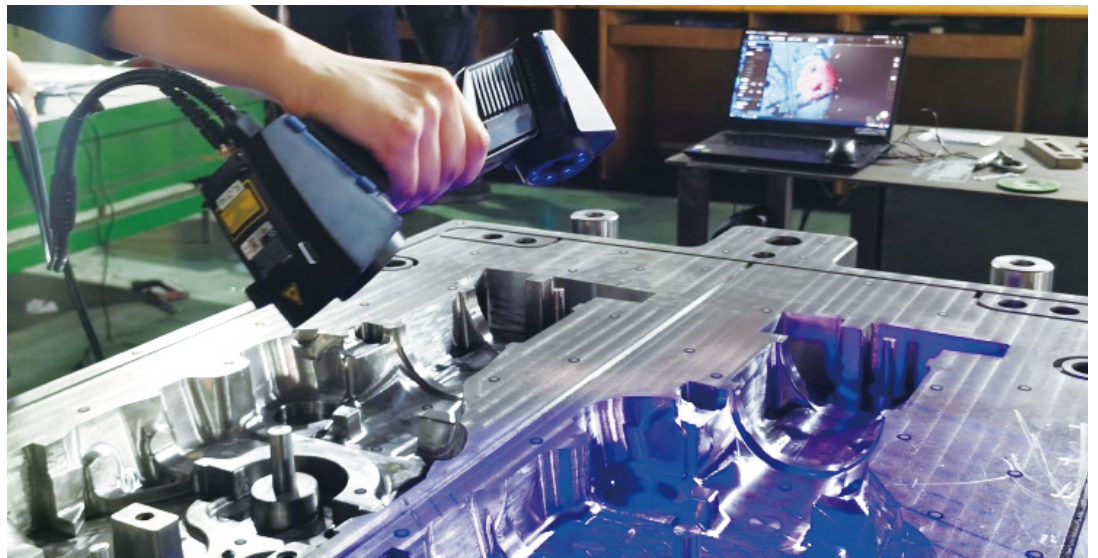

# About SHINING 3D

Founded in 2004, SHINING 3D is committed to democratize the 3D scanning technology and provide the 3D digitizing solution based on the understanding of customer and market's demand, creating powerful products in ease of use and accessible.

Intellectual Property

**440+**

SHINING 3D has independently researched and developed a number of core technologies in the 3D field, with **448** granted patents and **454** patents under application.

Team Size

**1,300+**

SHINING 3D has **1300+** employees, **40%** of which are R&D staff.

Scanners Sold

**200,000+**

SHINING 3D scanners are served to **55000+** users over **10000+** companies in more than **170** countries.

*\* Date Till December 30, 2024*

## Rigorous Product Quality Control System



## Valuing Data Security & Personal Information Protection



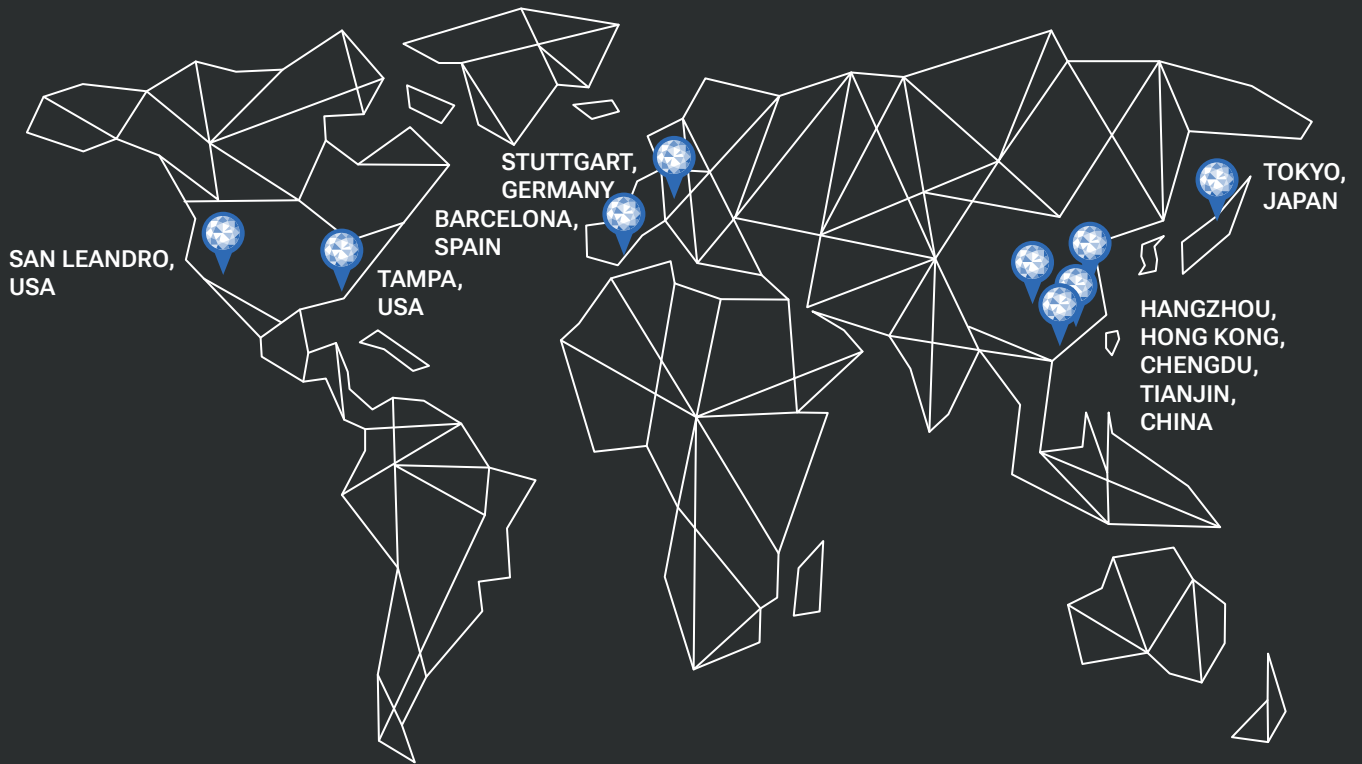

SAN LEANDRO,  
USA

TAMPA,  
USA

STUTTGART,  
GERMANY  
BARCELONA,  
SPAIN

TOKYO,  
JAPAN

HANGZHOU,  
HONG KONG,  
CHENGDU,  
TIANJIN,  
CHINA

### SHINING 3D Tech Co., Ltd.

- 📍 Hangzhou, China  
P: 400-0799-666  
No. 1398, Xiangbin Road, Wenyan,  
Xiaoshan, Hangzhou, Zhejiang,  
China, 311258

### SHINING 3D Technology GmbH.

- 📍 Stuttgart, Germany  
P: +49-711-28444089  
Breitwiesenstraße 28, 70565, Stuttgart, Germany
- 📍 Barcelona, Spain  
Calle 27, 10-16, Sector BZ, 08040 Barcelona, Spain

### SHINING 3D Technology Japan Inc.

- 📍 Tokyo, Japan  
Tradepia Odaiba 10F, 2-3-1 Daiba, Minato-ku,  
Tokyo, 135-0091 Japan  
TEL: 03-6380-7622

### SHINING 3D (HK) COMPANY LIMITED.

- 📍 Hong Kong, China  
P: 00852-23348468/23348568  
Room 303A, 3/F, Tower 2, Enterprise Square Phase 1,9  
Sheung Yue Road, Kowloon Bay, Kowloon, Hong Kong

### SHINING 3D Technology Inc.

- 📍 California, USA  
P: +1415-259-4787  
2450 Alvarado St #7, San Leandro, CA 94577
- 📍 Florida, USA  
Orange Grove Commerce Park 2807 W Busch Blvd



Facebook



Instagram



LinkedIn

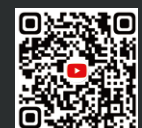

YouTube